

The Dealer's Choice

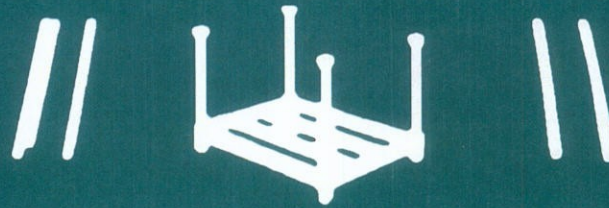

GATEWAY RACK



CORPORATION

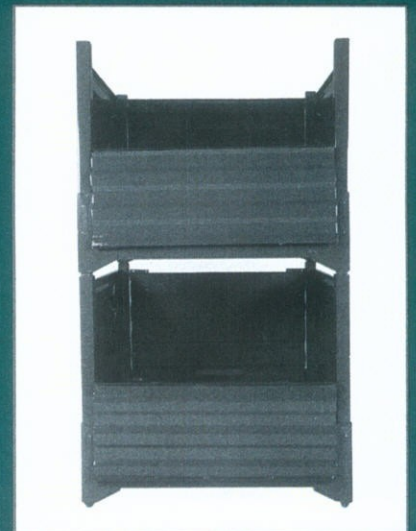
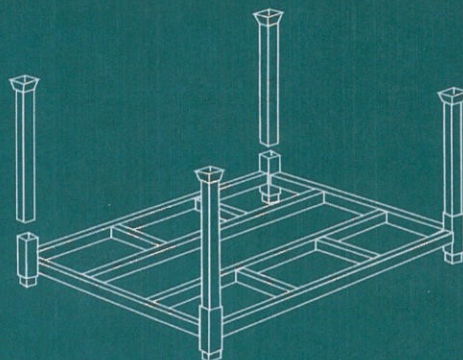
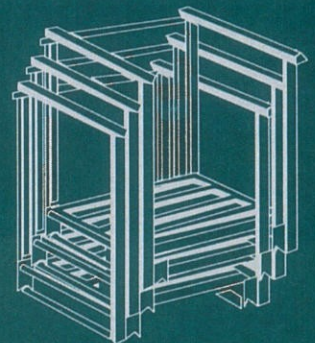
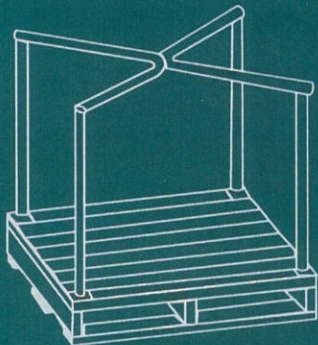

Pallet Stacking Frame

- Convert ordinary warehouse pallets
- Store difficult-to-handle products
- All sizes standard
- Easily stored when not in use
- Accommodates thousands of pounds

Bent with Pin

Corner Post

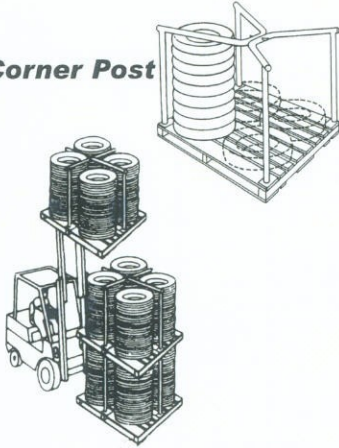

Center Post

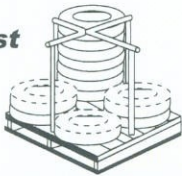

Set-Up

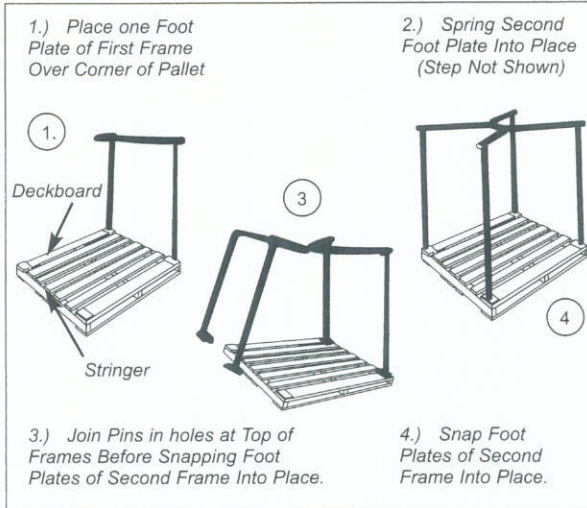

Over & Under

Corner Post

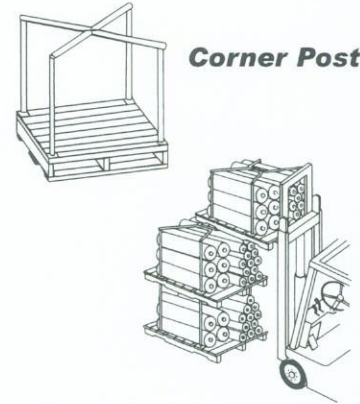

Center Post



Nestables

All-Welded Design

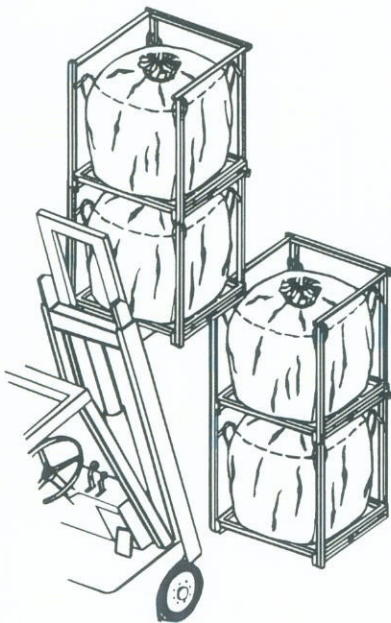

All Racks Nest Into One Another When Not In Use!

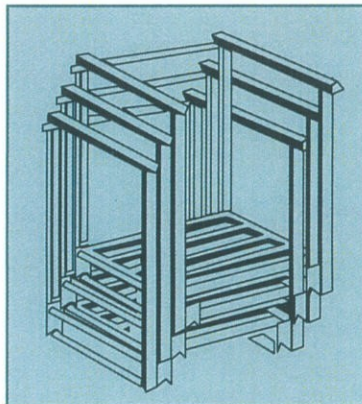

Removable Posts

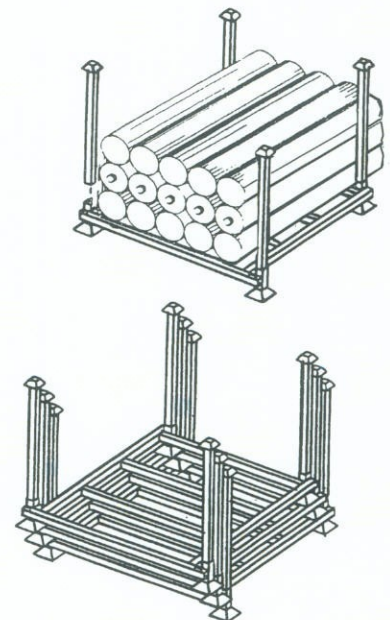

Portable Stacking Racks

TWO-WAY ENTRY

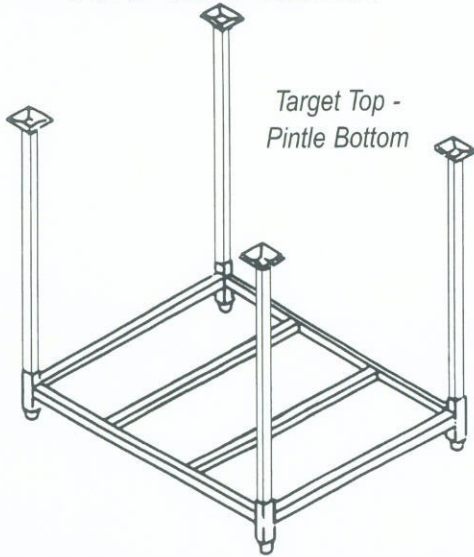

FOUR-WAY ENTRY

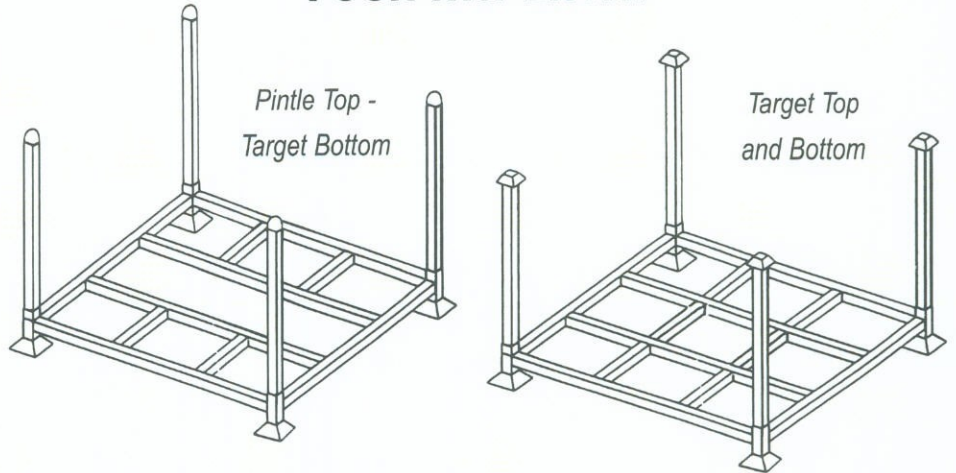

Removable Or Fixed Posts

Base Frame Styles

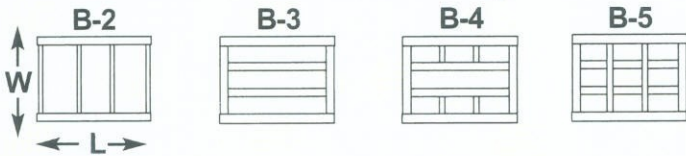

Decking Styles

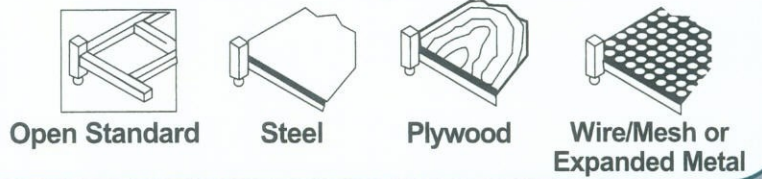

Organize & Protect

Heavy Duty Storage Side Panel Containment

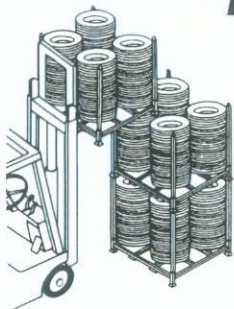

Stacks up to 4 & 5 High

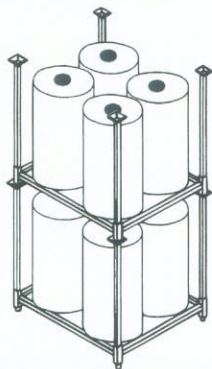

Flexible Storage

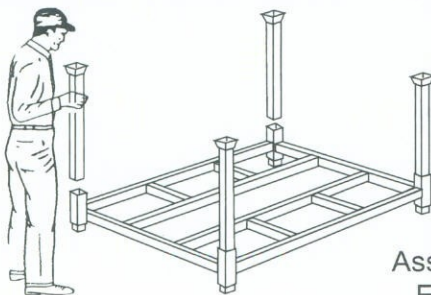
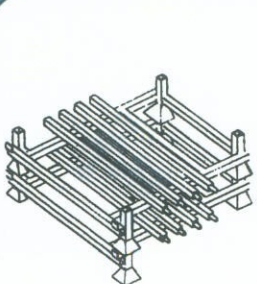
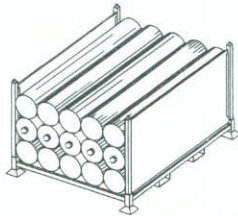

Assembles Easily!

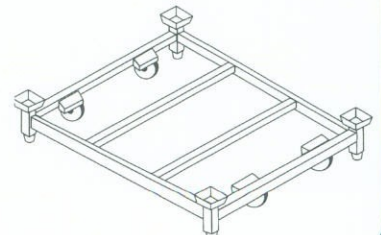
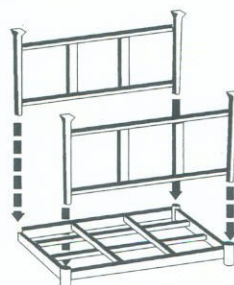

Custom Designs For Unique Products

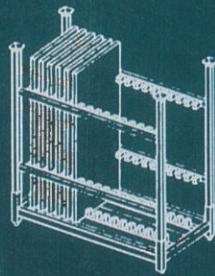
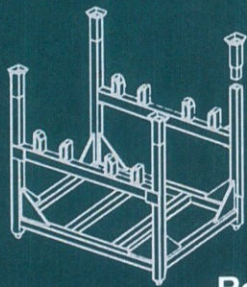

**Returnable
Shipping Racks**

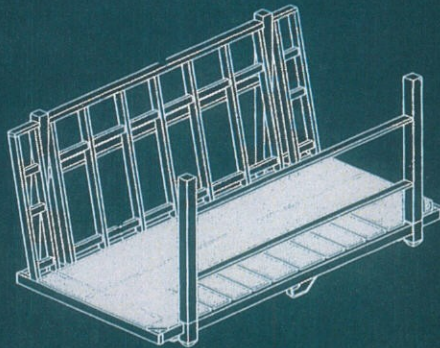
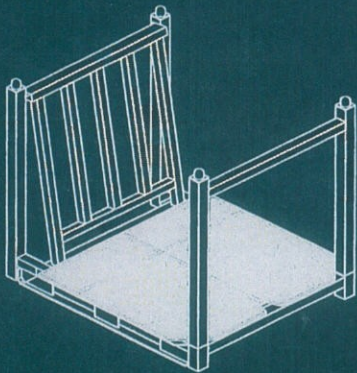

Rigid Wire and Corrugated Containers

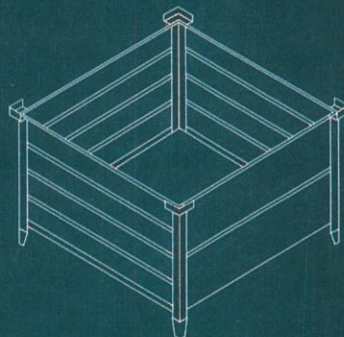
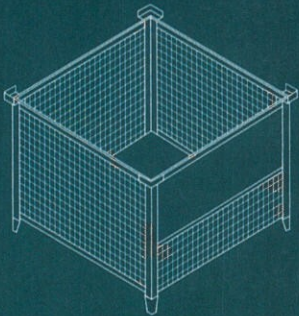

Rigid Wire and Corrugated Containers
Utilize Air Space, Save Floor Space

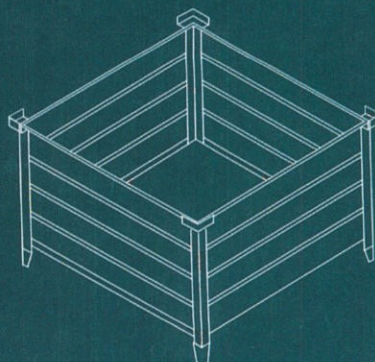
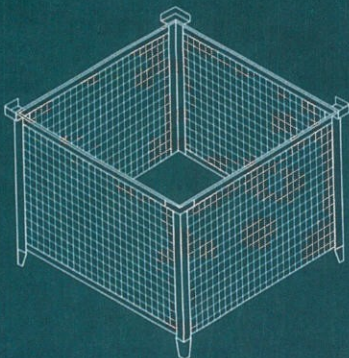

Mission Statement

The focus of Gateway Rack is to provide dealers material handling products that will exceed their customer expectations on delivery and durability.

Customer service will remain the cornerstone of our business and will be the driving force behind our continued growth.



Telephone (888) 288-9078

Fax (314) 381-5908

www.gatewayrack.com